

ASSEMBLY INSTRUCTION

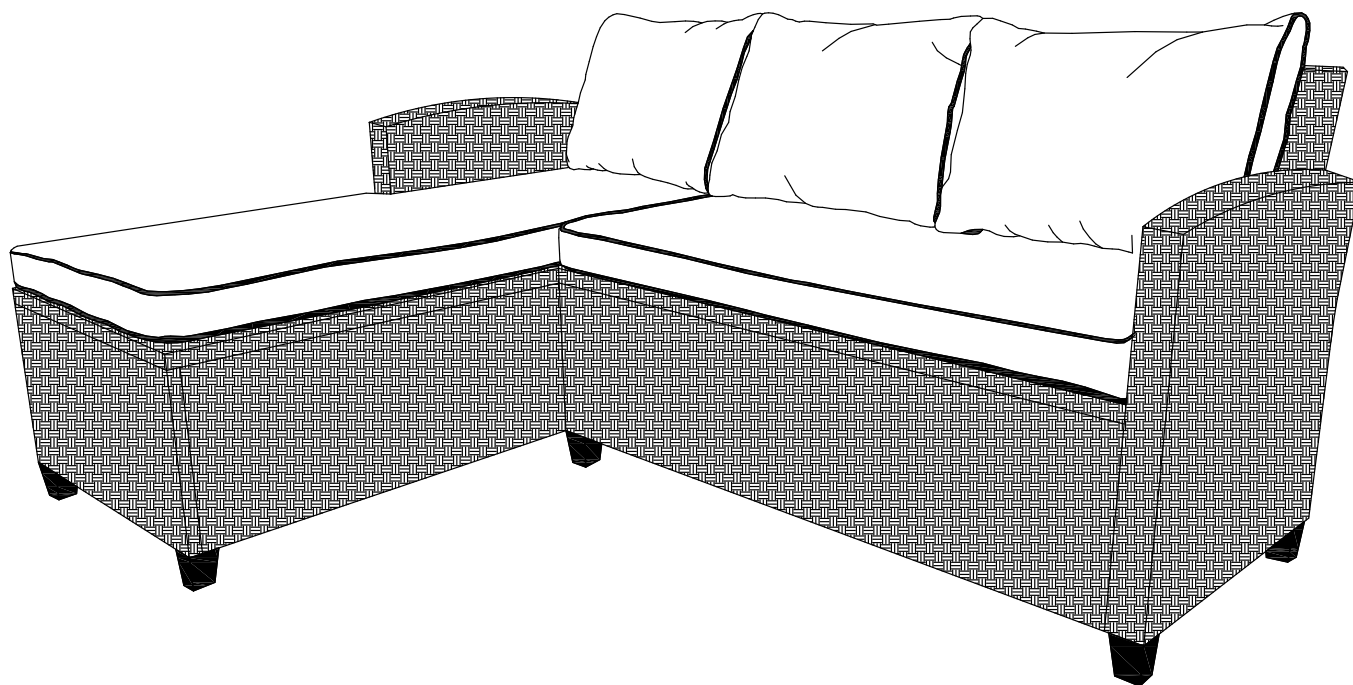

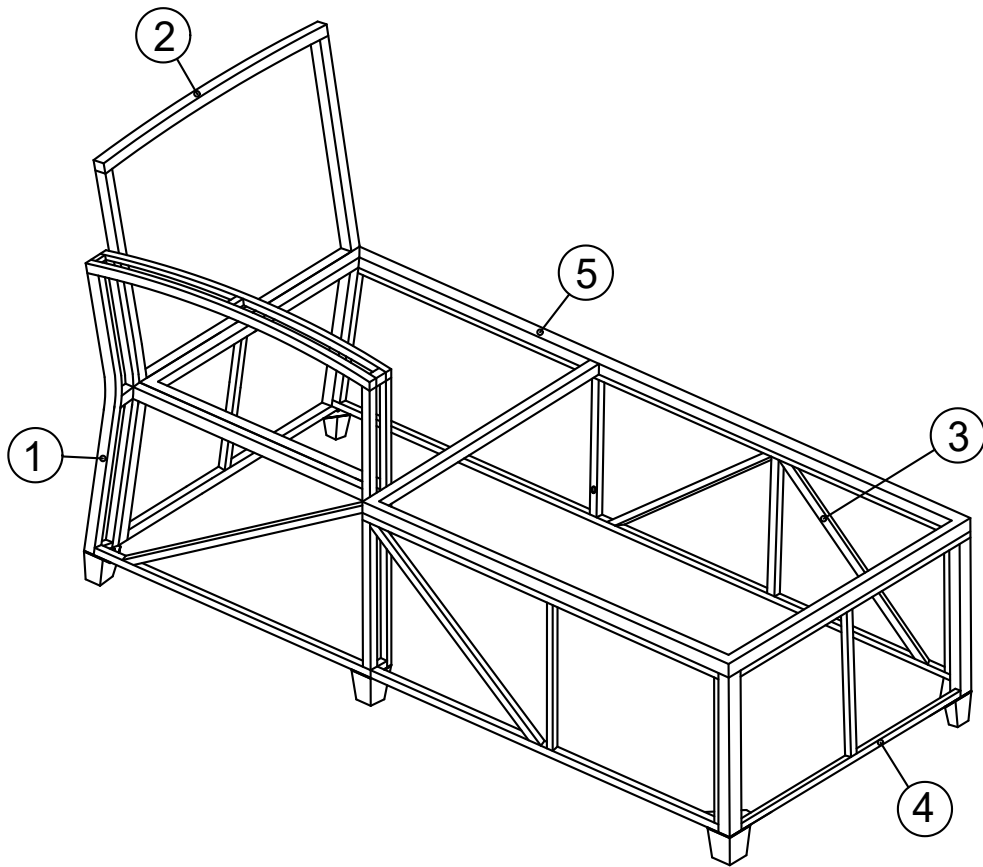

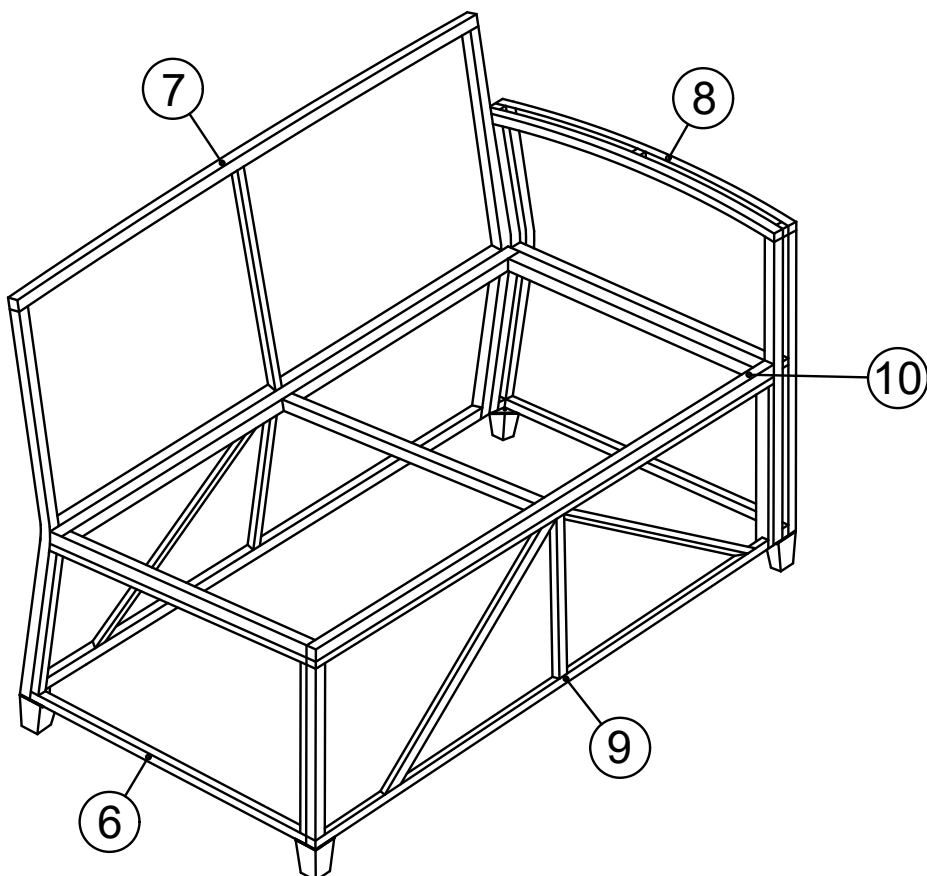





x1

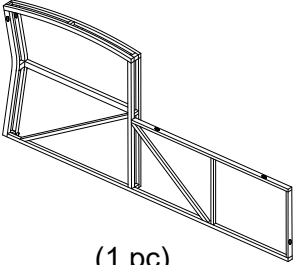
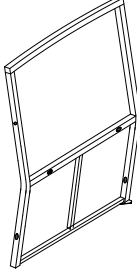
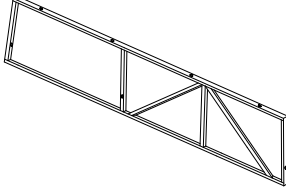
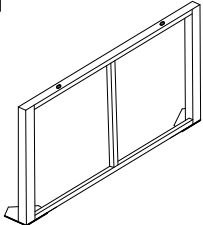
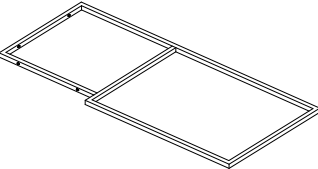
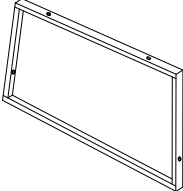
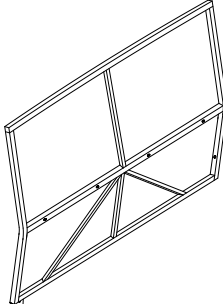
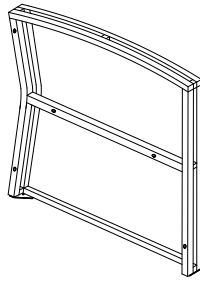
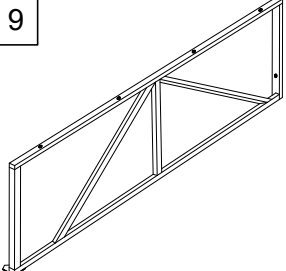
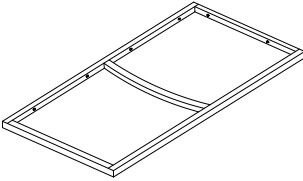
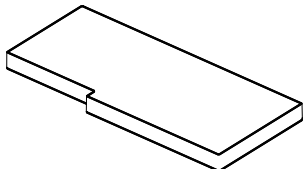
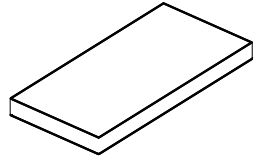
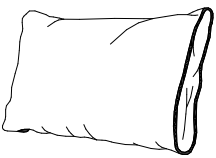

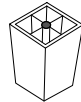
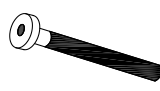



x1

Part List & Hardware

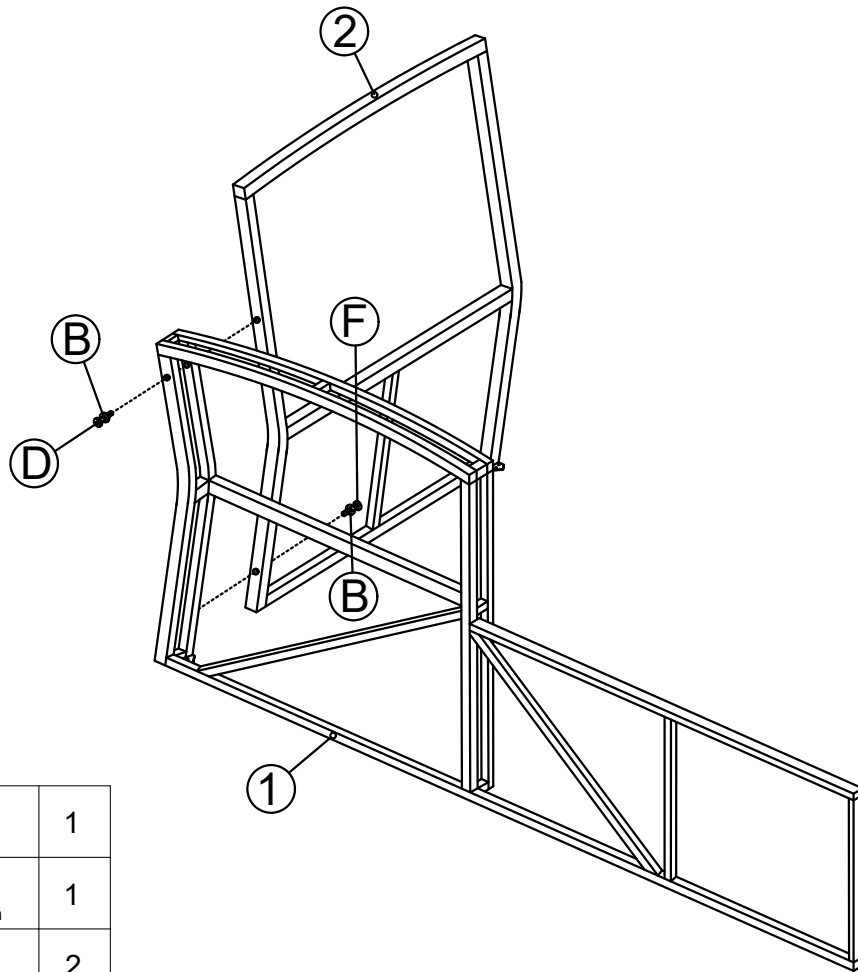
1  (1 pc)	2  (1 pc)	3  (1 pc)	4  (1 pc)
5  (1 pc)	6  (1 pc)	7  (1 pc)	8  (1 pc)
9  (1 pc)	10  (1 pc)	11  (1 pc)	12  (1 pc)
13  (3 pcs)			
A  Allen key 4 x 80 mm (2 pcs)	B  Ø6 x 16 mm (39 pcs)	C  (9 pcs)	D  M6x70 mm (2 pcs)
E  M6x60 mm (9 pcs)	F  M6x40 mm (21 pcs)	G  M6x30 mm (16 pcs)	



STEP 1

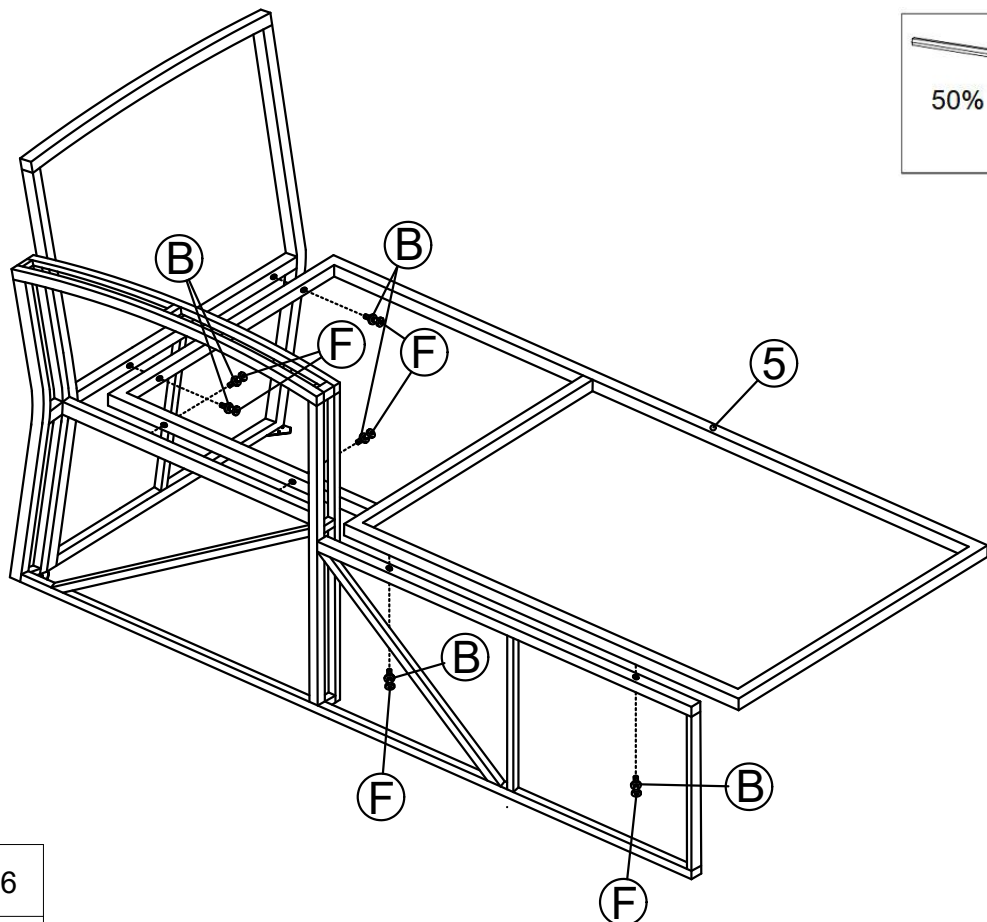

D	 M6 x 70 mm	1
F	 M6 x 40 mm	1
B	 Ø6 x 16 mm	2

STEP 2





F	 M6 x 40 mm	6
B	 Ø6 x 16 mm	6

C

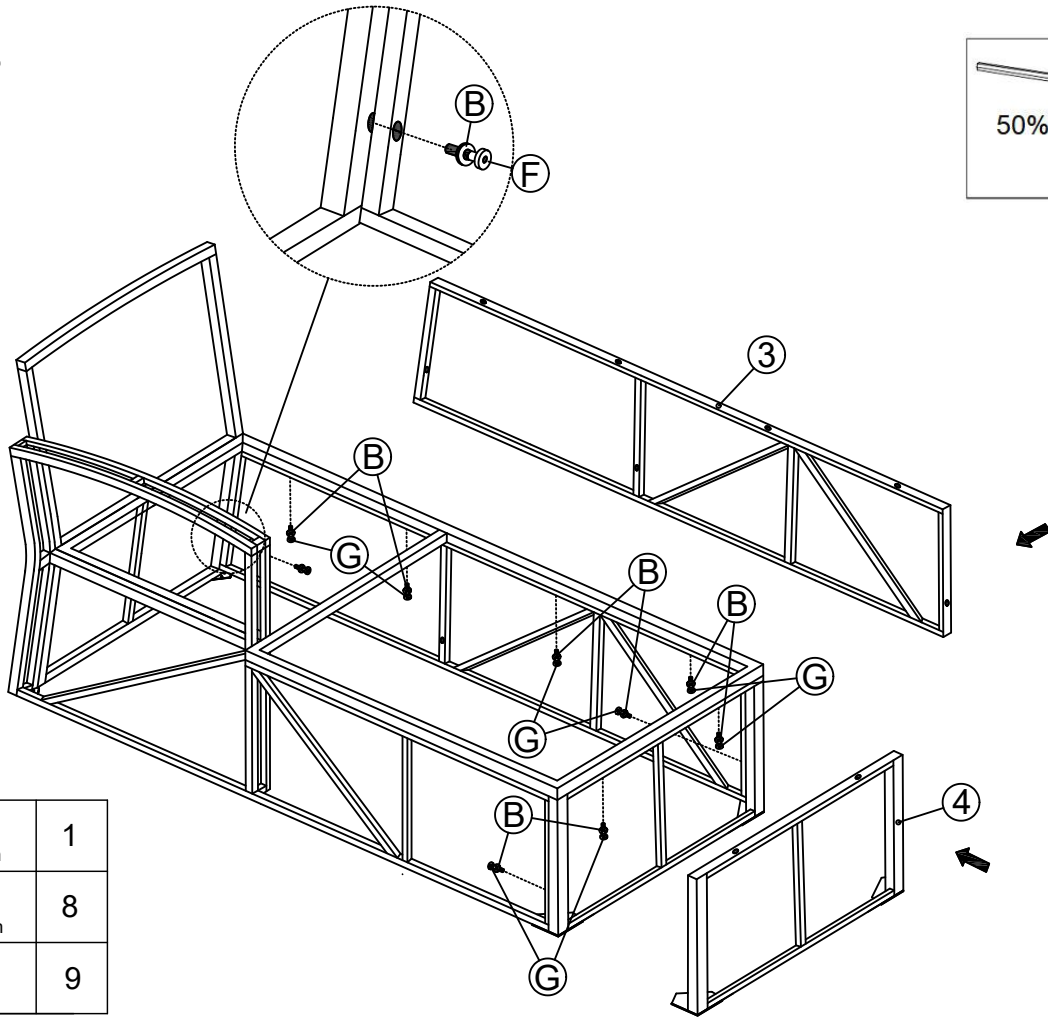

STEP 3

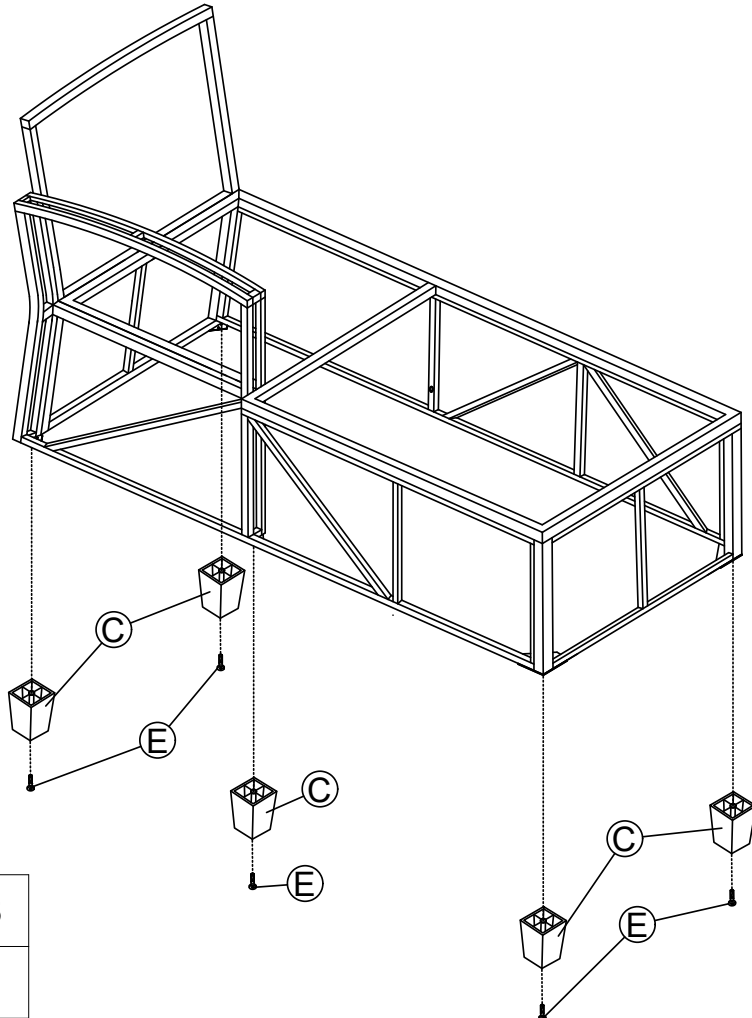

F	 M6 x 40 mm	1
G	 M6 x 30 mm	8
B	 Ø6 x 16 mm	9

STEP 4





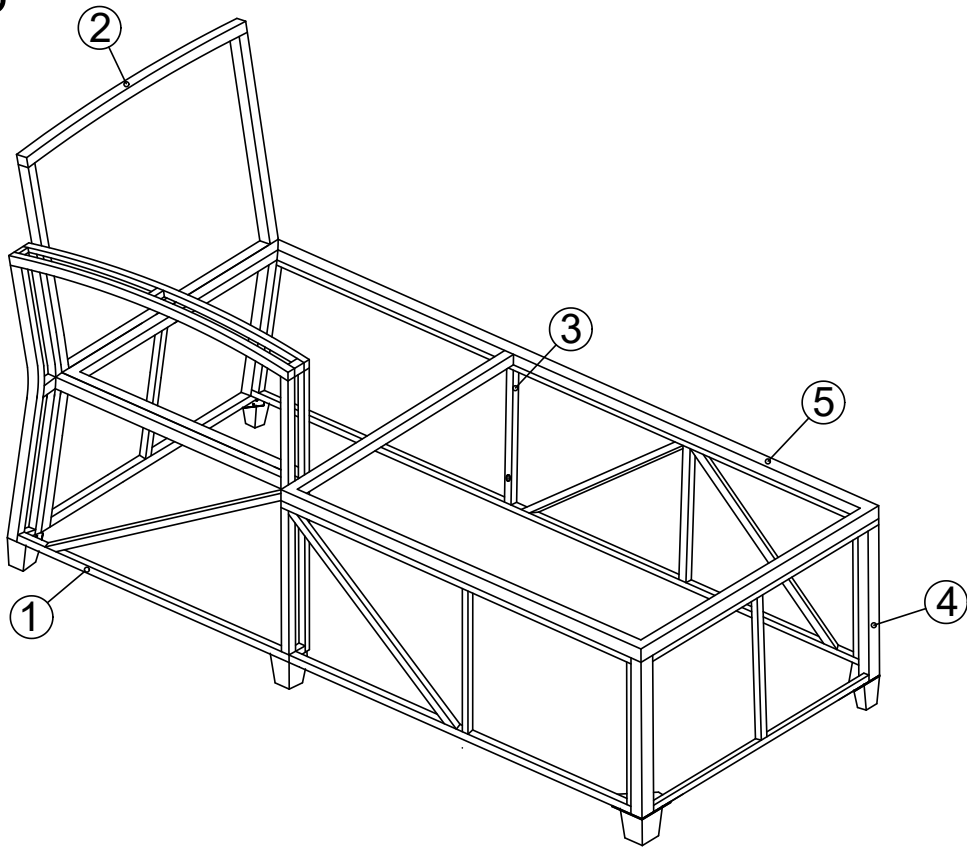

C		5
E	 M6 x 60 mm	5

STEP 5

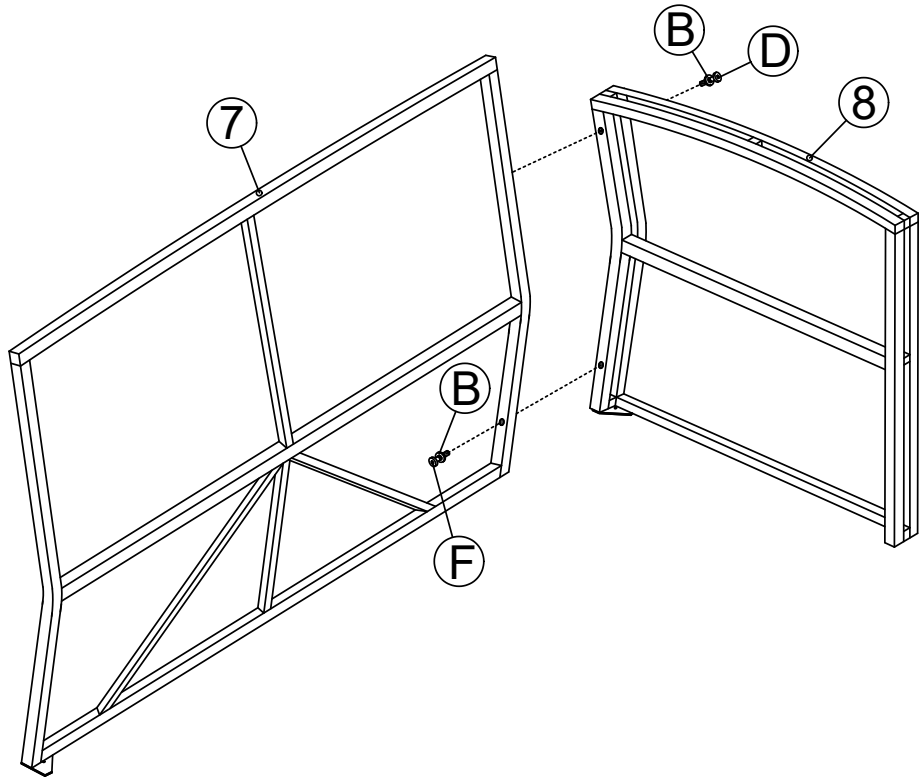

STEP 6



D	 M6 x 70 mm	1
F	 M6 x 40 mm	1
B	 Ø6 x 16 mm	2

STEP 7

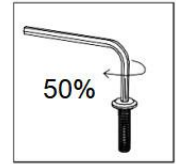
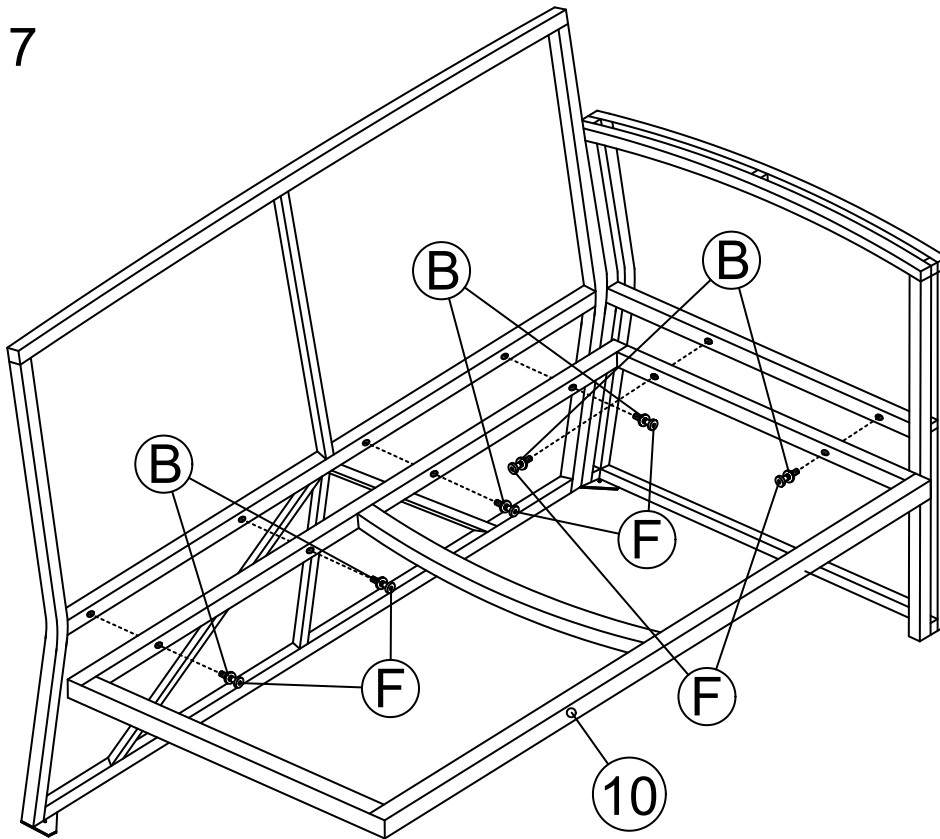

F	M6 x 40 mm	6
B	ø6 x 16 mm	6

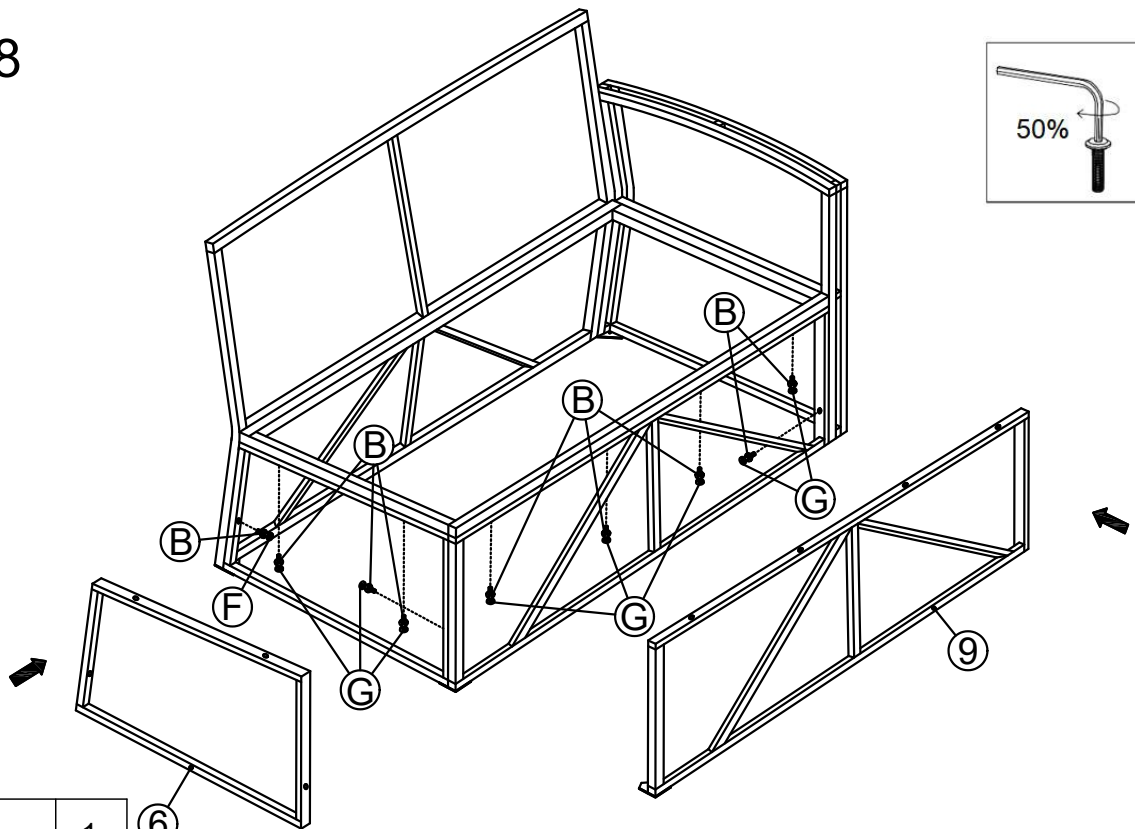

STEP 8

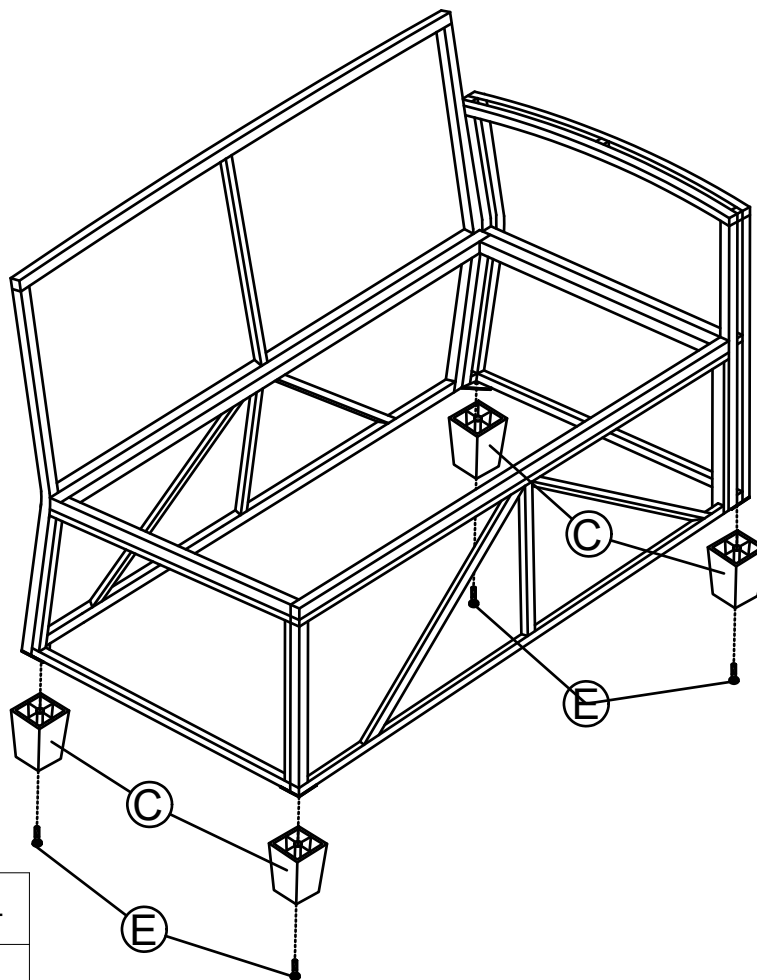

F	M6 x 40 mm	1
G	M6 x 30 mm	8
B	ø6 x 16 mm	9

STEP 9



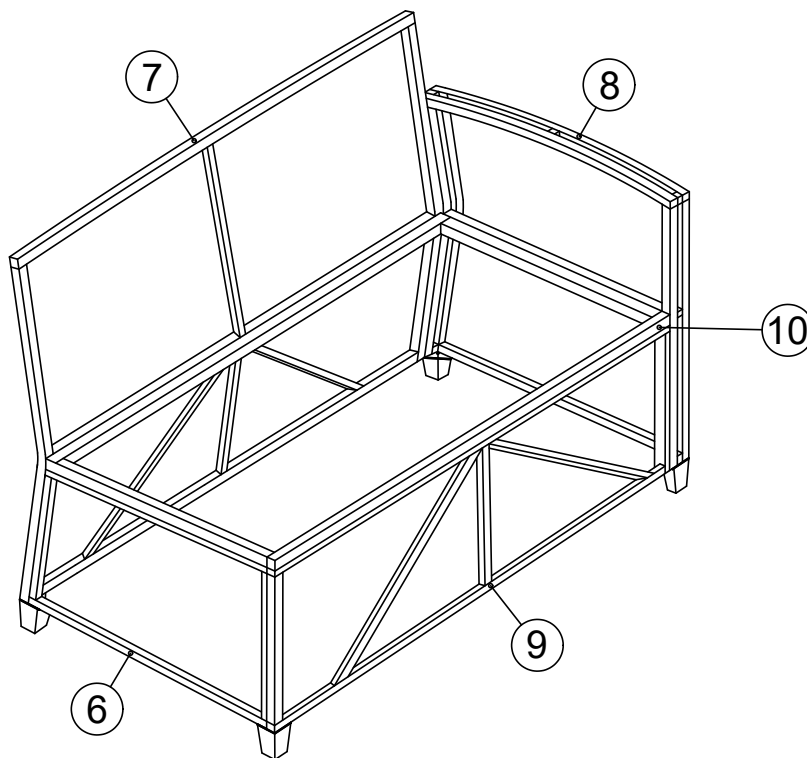

C		4
E	 M6 x 60 mm	4

STEP 10

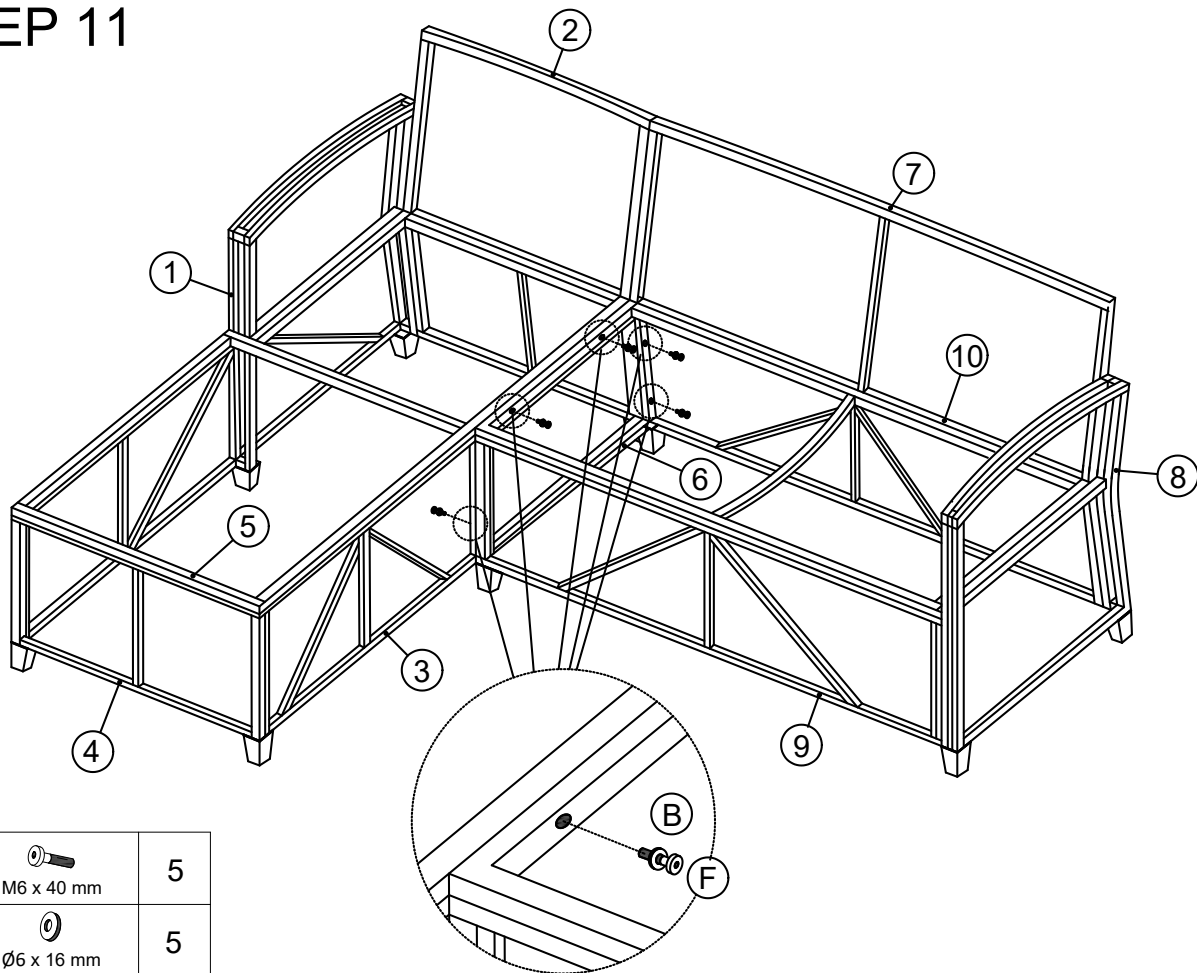

STEP 11



F	 M6 x 40 mm	5
B	 Ø6 x 16 mm	5

